

PDC Dull Grading

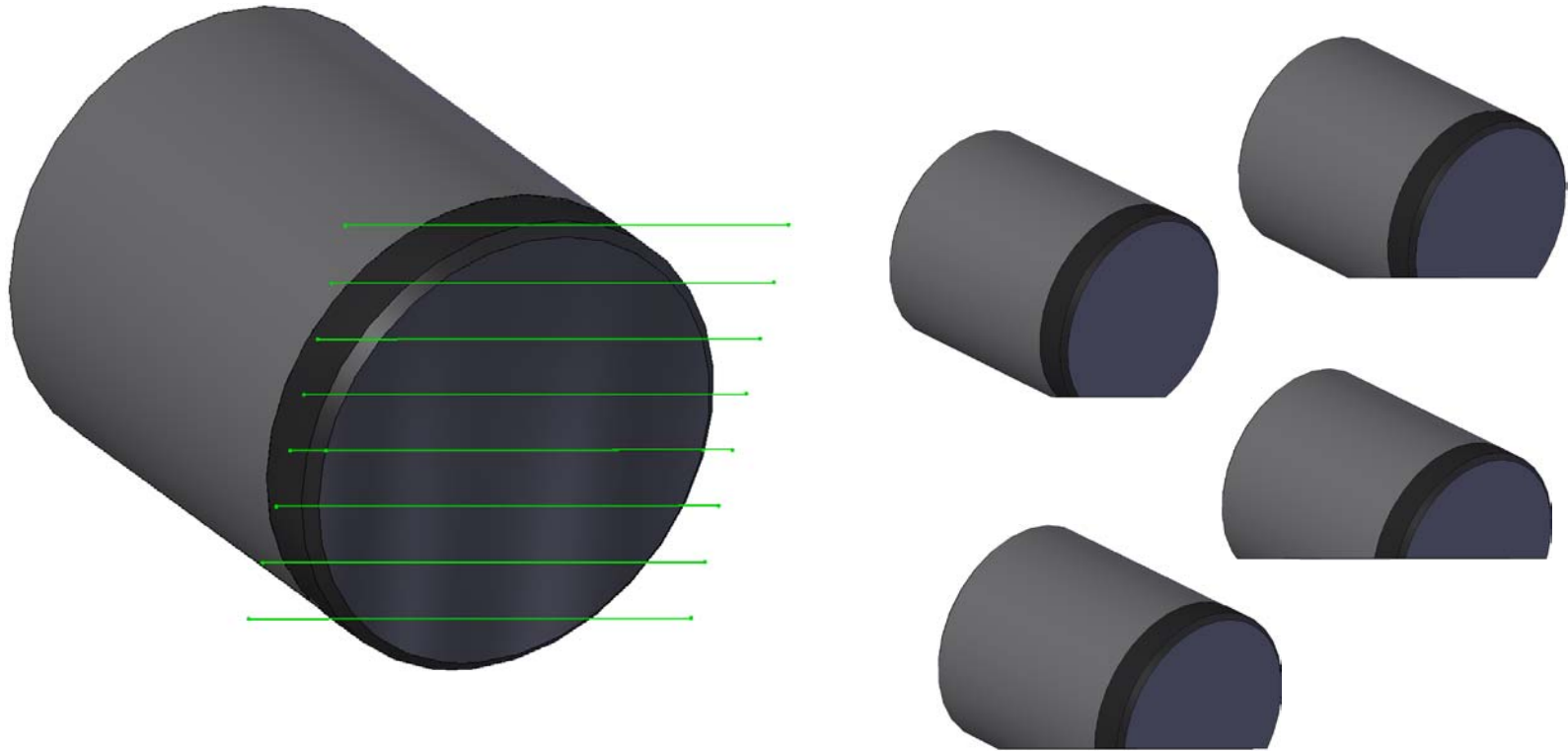

System

Inner	Outer	Dull Char	Location	Bearing Seals	Gauge	Other Dull Char	Reason Pulled
1	2	3	4	5	6	7	8

- 1: Inner Cutting Structure
- 2: Outer Cutting Structure
- 3: Primary Dull Characteristic
- 4: Location of Primary Characteristic
- 5: Bearing Seals (XXX for PDC. Only used for roller cone)
- 6: Amount Under Gauge
- 7: Other / Secondary Dull Characteristic
- 8: Reason Bit Was Pulled



Inner & Outer Cutting Structure

- Rating for both inner and outer cutting structure is given in a scale of 1 to 8.
- A rating of **1** states that 1/8 of the cutter's diamond table has been worn. A rating of **8** would mean that there is no effective diamond table left.
- An average rating for both the inner and outer cutting structure is entered for the first 2 positions of the dull grading code.

Inner & Outer Cutting Structure

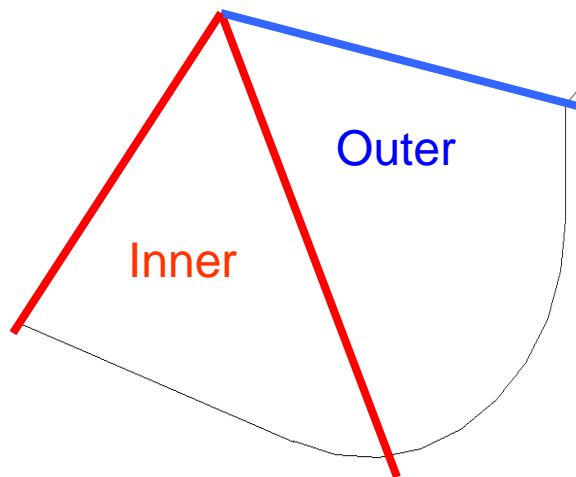
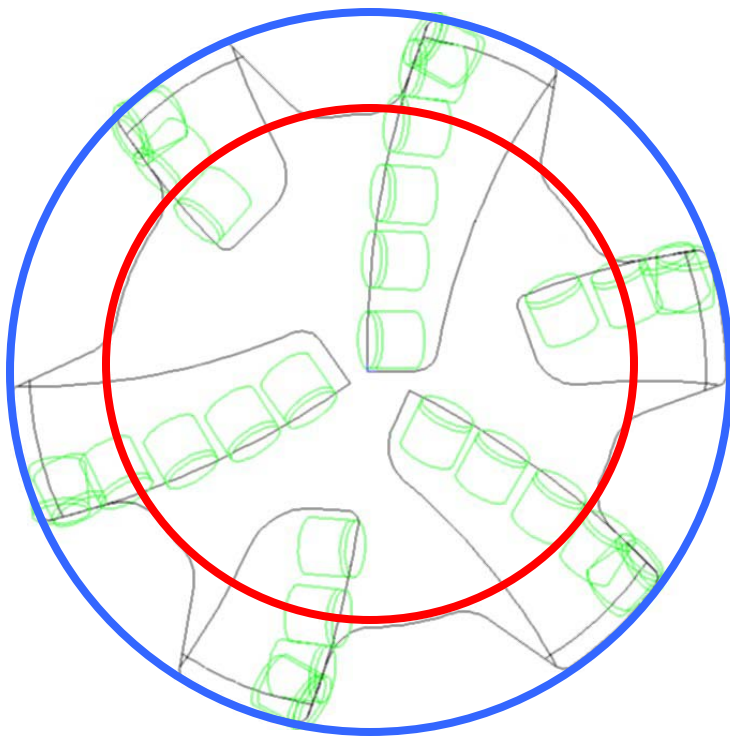

The inner cutting structure consists of the inner $\frac{2}{3}$ of the bit diameter whereas the outer consists of the final $\frac{1}{3}$.

A general rule of thumb is the inner number represents the cutters inside the nose and the outer represents those outside.

Inner & Outer Cutting Structure

Rating: Wear

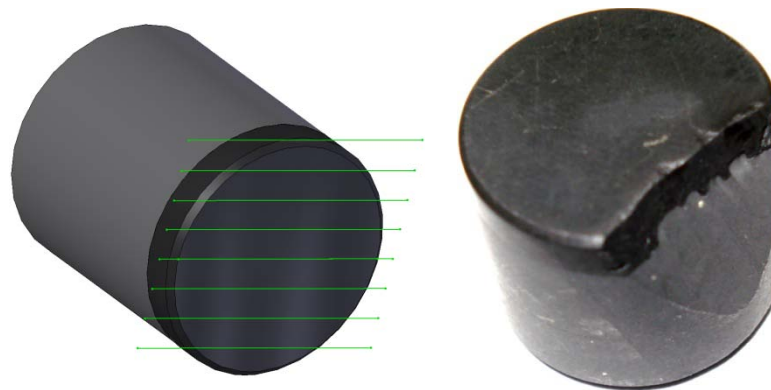
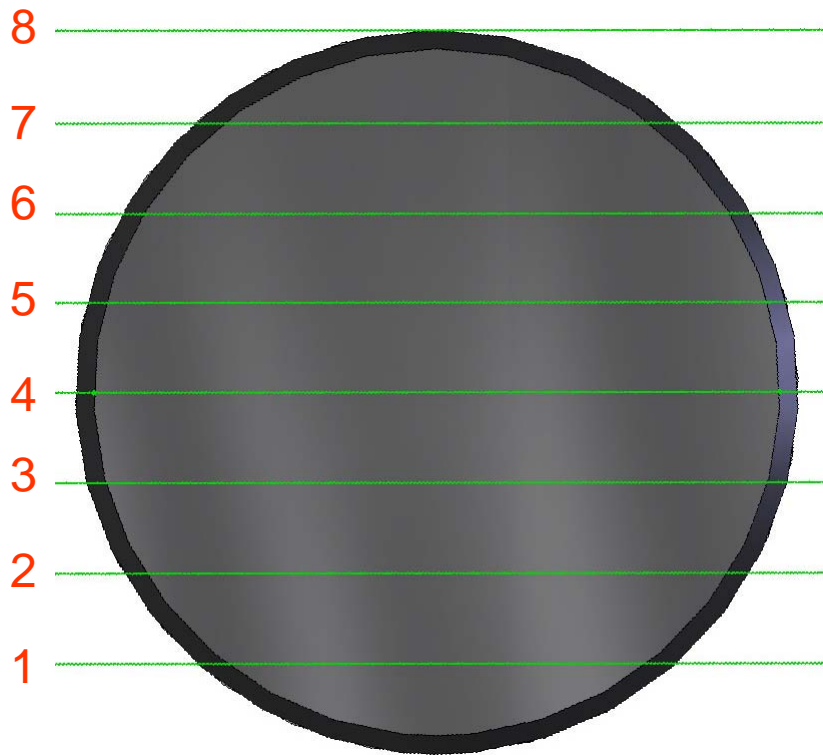

When dull grading pure wear, the 1 through 8 rating system can be followed exactly. However, in many cases, a wear flat less than 1/8 of the diamond table can be called a 1.

Inner & Outer Cutting Structure



When dull grading cutters with characteristics other than pure wear, take into consideration the amount of effective diamond table that is left. In many cases, cutters with a chipping condition can be graded the same as those with pure wear. As can be seen, spalling can be quite difficult to rate; while there is diamond missing almost halfway across the example above, there is still effective diamond remaining. A complete delam is always rated an 8.



Dull Characteristics

- When determining what dull characteristic to enter, find the most common dull type on the bit. In other words, what characteristic is the most likely cause of a decrease in performance?
- There will often be many characteristics present on a dull bit. Determining which was the primary cause of failure is key.
- If the bit is “green” and no dull condition exists, enter **NO** into the field.

Dull Characteristics

- **BC** – Broken Cutter*
- **BT** – Broken Teeth*
- **BU** – Balled up
- **CR** – Cored
- **CT** – Chipped Teeth / Cutters
- **DEL** – Delaminated Cutter
- **ER** – Erosion
- **HC** – Heat Checking
- **JD** – Junk Damage
- **LT** – Lost Teeth / Cutters
- **PN** – Plugged Nozzle
- **RO** – Ring Out
- **SP** – Spalled Cutter
- **WO** – Wash Out
- **WT** – Worn Teeth



* BC / BT

Erosion



Cored

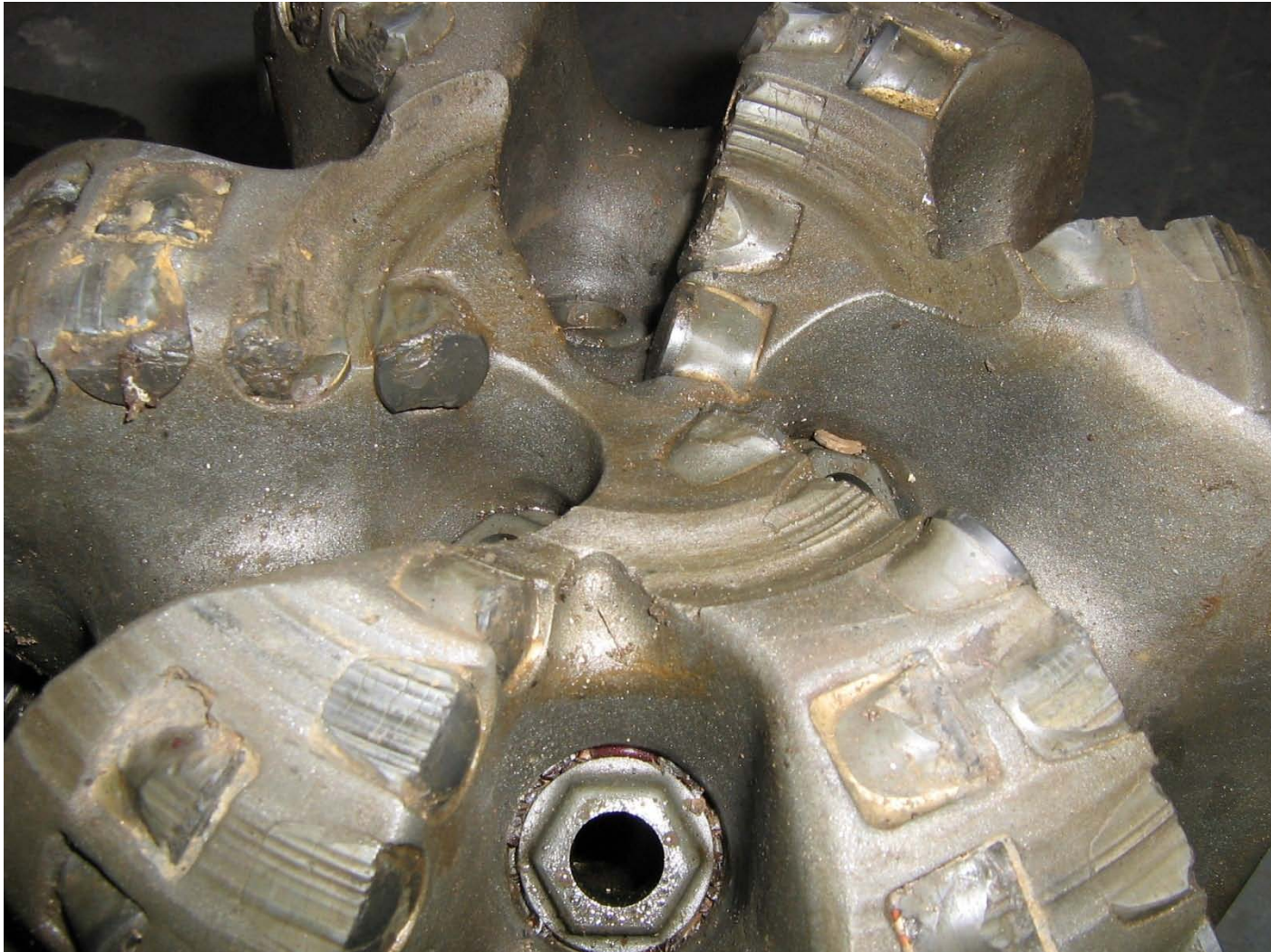

Dull Location

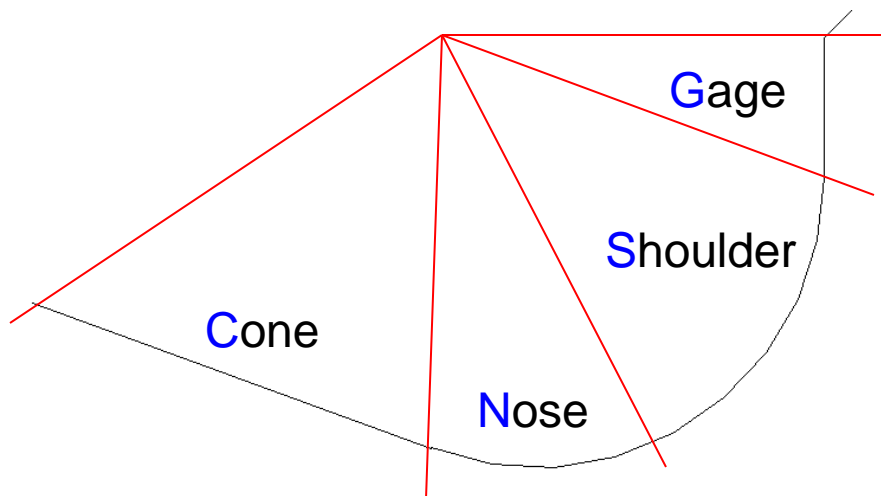

When the primary dull characteristic has been determined, enter the main location of this characteristic. For example, if **WT** is the primary dull condition and it occurred mostly on the shoulder of the bit, enter **S** into the field.

Gauge

- The gauge section of the dull grading system is represented by either **IN** or an integer beginning at **1**.
- **IN** means that the bit is still at full gauge.
- A value of **1** equals $1/16$ " under gage.
- A value of **2** equals $1/8$ ", **3** = $3/16$ ", Etc.

Gauge

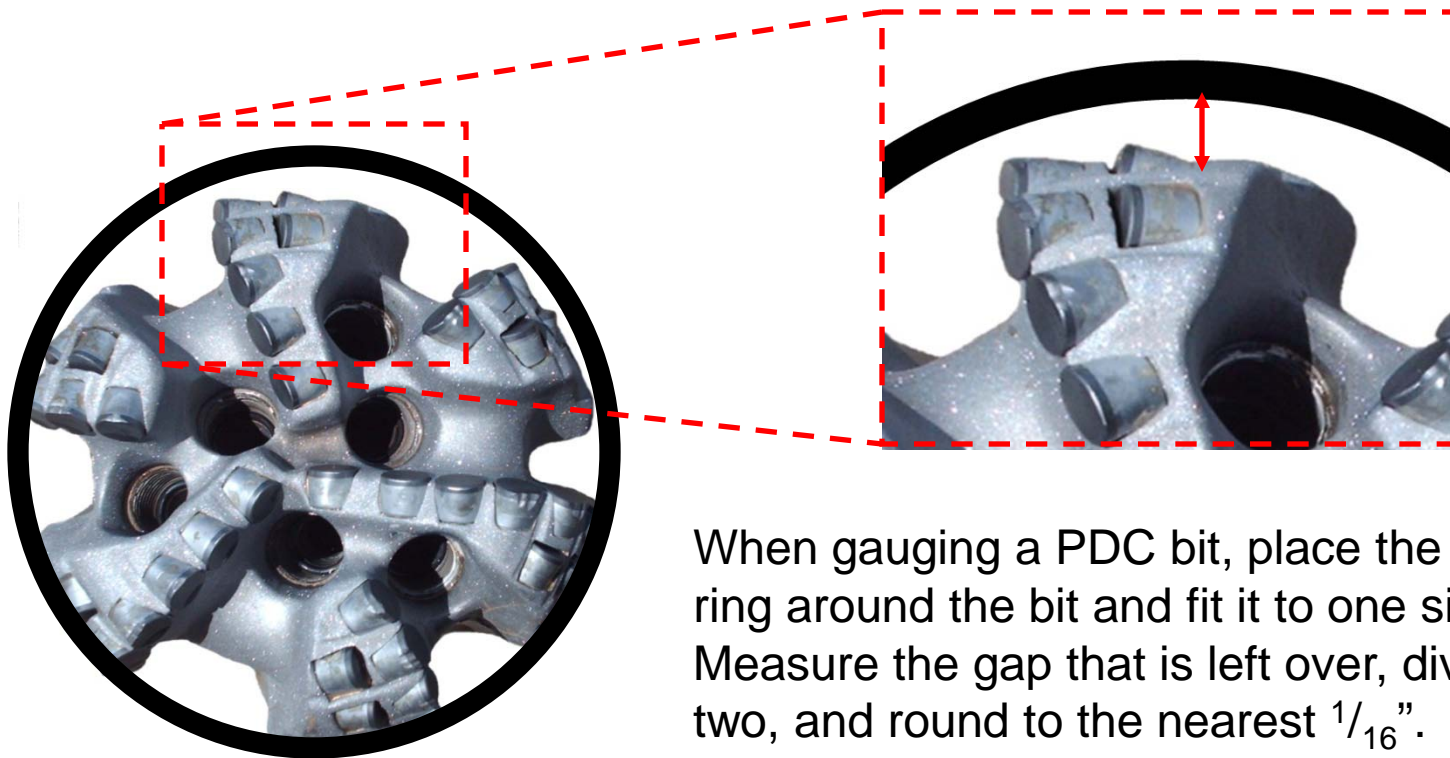

When gauging a PDC bit, place the gauge ring around the bit and fit it to one side. Measure the gap that is left over, divide by two, and round to the nearest $\frac{1}{16}$ ".

For example: If there is a $\frac{4}{16}$ " gap, then the bit is $\frac{2}{16}$ " or $\frac{1}{8}$ " under gauge. A value of **2** would then be entered into the gauge field.



Other Dull Characteristic

- In cases where there are multiple dull characteristics present on a bit, the “other” field can be used.
- After the primary dull characteristic has been determined, find the secondary condition and enter its code in the field.
- If there is no other dull condition, enter **NO** into the field.



Reason Pulled

- Whenever a bit is pulled, there must be a reason. Whether it is due to penetration rate, motor failure, or total depth being reached, this is a very important field.
- Often times a bit is pulled due to something other than failure of the cutting structure. Also, failures within the BHA can lead to severe bit damage. Immediately knowing why the bit was pulled will aid in determining the overall performance.

Reason Pulled

- **BHA** – Change the bottom hole assembly
- **DMF** – Down hole motor failure
- **DTF** – Down hole tool failure
- **DSF** – Drill string failure
- **DST** – Drill stem test
- **DP** – Drill Plug
- **CM** – Condition Mud
- **CP** – Core Point
- **FM** – Formation change
- **HP** – Hole problems
- **LIH** – Left In Hole
- **LOG** – Run logs
- **PP** – Pump Pressure
- **PR** – Penetration Rate
- **RIG** – Rig repair
- **TD** – Total / casing Depth
- **TW** – Twist Off
- **TQ** – Torque
- **WC** – Weather Conditions

Examples



0 1 WT S XXX IN NO TD

Examples



1 3 WT S XXX IN CT TD

Examples



1 4 CT S XXX 1 WT PR

Examples



3 6 BC N XXX IN SP PR

Examples



2 6 RO S XXX IN BC DMF



2 8 RO N XXX IN WT FM